

Support bracket + Accessories

10-222B + 10-222A/...

1 General Information

Product Name:	Support bracket
Product Type:	Load holding device
Product Number:	10-222B
Weight:	15.25 kg
Maximum Load Capacity:	428 kg
Static Test Coefficient:	3.0

Intended Use:

- ▶ For supporting various vehicle components according to the workshop manuals of the Volkswagen Group brands.

Terms of Use:

- ▶ Only for qualified workshop personnel.
- ▶ Only use the load holding device for work approved by the Volkswagen Group.
- ▶ Only use for loads up to 428 kg.
- ▶ The maximum load capacity of the individual accessories must not be exceeded.
- ▶ Do not hold or lift any persons or animals.
- ▶ Do not hold or lift articles other than those described in the workshop manuals of the Volkswagen Group brands.
- ▶ Do not stand under suspended loads.
- ▶ Use only in connection with the approved accessories (see workshop manuals of the Volkswagen Group brands).

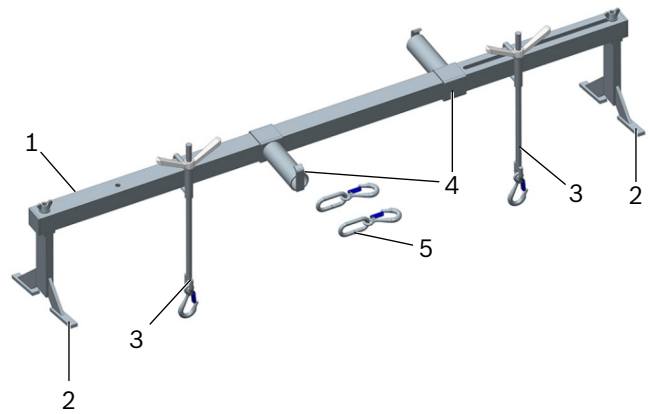

Fig. 1: Support bracket 10-222B

- 1 Cross beam 10-222A/100
- 2 Supporting feet 10-222A/1A
- 3 Holder 10-222A/101
- 4 Adapter 10-222A/3
- 5 Hook 10-222A/2











Equipment:

Product Number:	Name:	Weight:	Maximum Load Capacity:
10-222A/1A	Supporting feet (2x)	1.425 kg/piece	332 kg/piece
10-222A/2	Hook (2x)	0.25 kg/piece	332 kg/piece
10-222A/3	Adapter (2x)	0.90 kg/piece	287 kg/piece
10-222A/100	Cross beam	8.00 kg	428 kg
10-222A/101	Holder (2x)	1.05 kg/piece	332 kg/piece

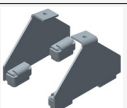

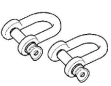
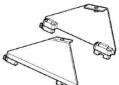

Available Accessories:

NOTICE

The accessories listed below may be used only with original parts of the Support bracket 10-222B.
The accessories may be used only as described in the workshop manuals of the Volkswagen Group brands.
The maximum load capacity of the individual accessories must not be exceeded.

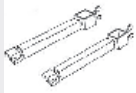
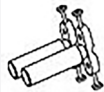
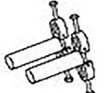
Product Number:	Figure:	Weight:	Maximum Load Capacity:	Description:
10-222A/4		2.15 kg/ piece	280.5 kg/piece	Adapter for supporting the cross beam 10-222A/100
10-222A/5		0.87 kg/ piece	153 kg/piece	Adapter for cross beam 10-222A/100
10-222A/6		2.17 kg/ piece	306 kg/piece	Adapter for cross beam 10-222A/100
10-222A/7		0.73 kg	332 kg	Extension
10-222A/8		1.51 kg/ piece	229.5 kg/piece	Adapter for cross beam 10-222A/100
10-222A/9		2.4 kg	357 kg/piece	Adapter for right longitudinal beam and battery console for cross beam 10-222A/100
10-222A/9-1		4 kg	357 kg/piece	
10-222A/10		0.98 kg	332 kg	Fixture
10-222A/12		0.12 kg/ piece	332 kg/piece	Shackle for suspending the engine
10-222A/13		1.93 kg/ piece	254.5 kg/piece	Adapter for cross beam 10-222A/100
10-222A/14		1.6 kg	663 kg in connection only with 10-222A/15	Adapter for cross beam 10-222A/100

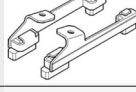
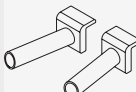
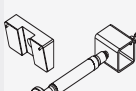
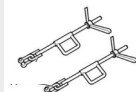
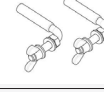
Product Number:	Figure:	Weight:	Maximum Load Capacity:	Description:
10-222A/15		3.01 kg	663 kg in connection only with 10-222A/14	Adapter for cross beam 10-222A/100
10-222A/16 10-222A/16-1		2.82 kg	175 kg	Adapter with 90° boom for setting on 10-222A/100 and hook 10-222A/16-1
10-222A/17		0.5 kg/piece	500 kg/piece	Distance piece for threaded spindle
10-222A/18		1.5 kg	260 kg long side, 408 kg short side, 306 kg both sides together	Adapter for cross beam 10-222A/100
10-222A/19		1.14 kg/piece	204 kg/piece	Adapter for right and left longitudinal beam for cross beam 10-222A/100
10-222A/20		0.17 kg/piece	200 kg/piece	Hook
10-222A/21		3.22 kg/piece	229.5 kg/piece	Adapter for right and left strut mounting for cross beam 10-222A/100
10-222A/22		1.29 kg/piece	306 kg/piece	Adapter for cross beam 10-222A/100
10-222A/23		4.42 kg/piece	358 kg/piece	Adapter for right and left strut mounting as well as lock carrier for cross beam 10-222A/100
10-222A/23-1		2.09 kg/piece	358 kg/piece	
10-222A/25		1.73 kg/piece	357 kg/piece	Adapter for cross beam 10-222A/100
10-222A/26		1.93 kg/piece	153 kg/piece	Adapter for cross beam 10-222A/100
10-222A/27		0.05 kg	332 kg	Hexagon nut, fitting only for spindle 10-222A/10 or 10-222A/101

Product Number:	Figure:	Weight:	Maximum Load Capacity:	Description:
10-222A/28		3.41 kg/piece	306 kg/piece	Adapter for cross beam 10-222A/100 and T40091/1
10-222A/28-1		0.4 kg/piece	306 kg/piece	Adapter for 10-222A/28
10-222A/28-2		0.5 kg/piece	306 kg/piece	
10-222A/29		1.45 kg/piece	306 kg/piece	Adapter for cross beam 10-222A/100
10-222A/30		0.95 kg/piece	306 kg/piece	Adapter for cross beam 10-222A/100
10-222A/31A		5.14 kg/set	204 kg/piece (10-222A/31-1 and -2)	Adapter for cross beam 10-222A/100
			408 kg/piece (10-222A/31-3 and -5)	Adapter for T40091/1
10-222A/32		0.97 kg/piece	332 kg/piece	Fixture
10-222A/34		0.25 kg/piece	30 kg/piece	Adapter for 10-222A/1A
10-222A/35		1.61 kg/piece	221 kg/piece	Adapter for cross beam 10-222A/100
10-222A/36		1.87 kg/piece	229.5 kg/piece	Adapter for cross beam 10-222A/100

2 General Safety Instructions

WARNING

Read and follow all safety notes and instructions!

Failure to follow the safety instructions may result in serious injuries and material damages.

- ▶ Observe and follow the safety notes below.
-
- ▶ The load holding device has been specifically constructed for its intended use. The safety of the load holding device can no longer be ensured if it is misused or modified in ways not expressly approved by the manufacturer. Serious injuries or damage to property can occur.
 - ▶ Ensure that each person using the load holding device is familiar with these instructions and can access them at all times.
 - ▶ Ensure that all users are also familiar with the operating manuals of all tools and workshop equipment, which are necessary for the work.
 - ▶ Carefully read and adhere to the instructions in the technical safety information of the brands of the Volkswagen Group.
 - ▶ For use only by qualified personnel on vehicles with gas drive or high-voltage components.
 - ▶ Observe and follow the basic information and safety notes for vehicles with gas drive in the corresponding Volkswagen Group information media when using on vehicles with gas drive.
 - ▶ Observe and follow the basic information and safety notes for high-voltage vehicles in the corresponding Volkswagen Group information media when using on vehicles with high-voltage components.
 - ▶ Wear safety shoes (according to ISO 20345, S2).
 - ▶ Wear protective gloves in order to avoid cuts.
 - ▶ Position hands and feet carefully to avoid potential crushing hazards.
 - ▶ Use the load-holding device only for work expressly approved by Volkswagen Group.
 - ▶ Use the load-holding device only with the accessories approved by the Volkswagen Group.
 - ▶ Do not exceed the maximum load capacity of 428 kg.
 - ▶ Do not exceed the permissible loads of the individual parts according to the tables “Included in Delivery” and “Available Accessories.”
 - ▶ Check the safety devices on the load hooks for their function.
 - ▶ Check all movable parts for function and ease of operation.
 - ▶ When using shackles ensure that the shackle bolts are screwed in correctly.
 - ▶ Only move the wing nuts of the threaded spindles by hand, without a fitted extension and only by one person.
 - ▶ Subject the threaded spindles and extensions for threaded spindles to tension only vertically.
 - ▶ Observe the installation position (right and left) with supporting feet and other adapters.
 - ▶ Ensure that all required parts are screwed securely and secured to the cross beam.
 - ▶ Move the load slowly and carefully.
 - ▶ Observe the Support bracket as well as the load during all movements.

3 Operating Instructions

1. When working on vehicles with high-voltage components, ensure the high-voltage system is de-energised according to the workshop manuals before working on the vehicle.

WARNING

Risk of electric shock!

Vehicles with high-voltage components have a high-voltage source. High voltage can cause serious personal injury and severe damage to materials.

- ▶ Observe the hazard classification of the high-voltage system in the workshop manual.
- ▶ Observe and follow the advice and work instructions in the workshop manual.

2. Check the support bracket and the required accessories for visible damage such as signs of wear, deformation, breakages, cracks, and corrosion damages prior to each use. Check all threads, rubber coatings, and axial bearings for damage. If defects are noted on the support bracket, do not use it and immediately discard it.
3. Carry out the necessary preparation work for the attachment of the load in accordance with the workshop manuals.
4. Install the support bracket with the required accessory parts as described in the workshop manual.
5. Position the support bracket on the vehicle as described in the workshop manual.
6. Suspend the load hooks in the reception eyelet or the reception eyelets at the vehicle component and secure them if necessary.

WARNING

Risk of the load swiveling or falling!

Incorrect attachment of the load on the support bracket may result in swiveling or falling of the load. This could cause serious personal injury and severe damage to materials.

- ▶ Fasten the load to the support bracket exactly as described in the workshop manuals, in order to avoid falling of the load.

7. Carry out further work as described in the workshop manuals.

CAUTION

Risk of injury through parts of the support bracket!

When the support bracket is positioned on the vehicle, persons can bump into it and hurt themselves.

- ▶ Exercise particular caution when working in the engine compartment.

8. Ensure that all parts of the special tool have been removed after completing the repair work.

3.1 Adapter 10-222A/3

- ▶ The safety stop must always point upward.

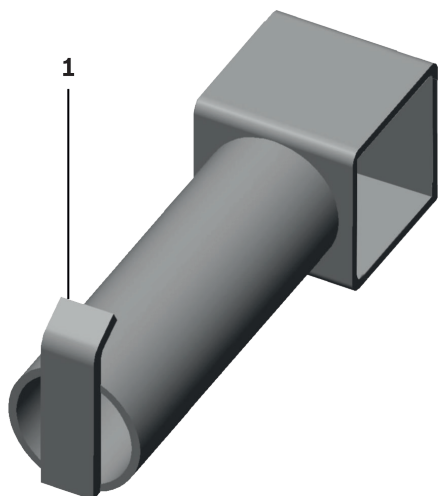

Fig. 2: Adapter 10-222A/3

1 Safety stop

3.2 Adapter 10-222A/16

- ▶ Position the load attaching device at the boom in such a manner that slipping is prevented.
- ▶ The boom may not project from the slot in the guide tube under load.

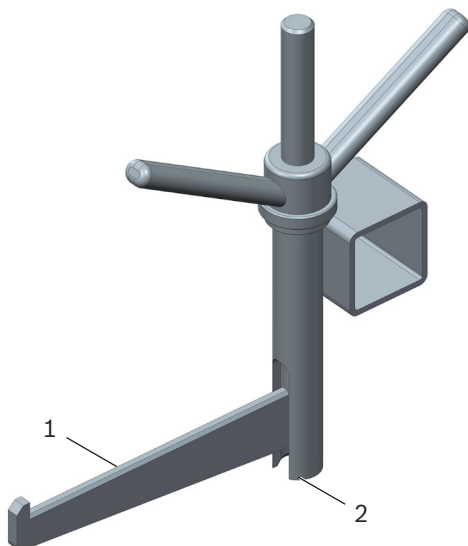

Fig. 3: Adapter 10-222A/16

1 Boom

2 Guide tube with slot

3.3 Adapter 10-222A/18

- ▶ The safety stop must always point upward.

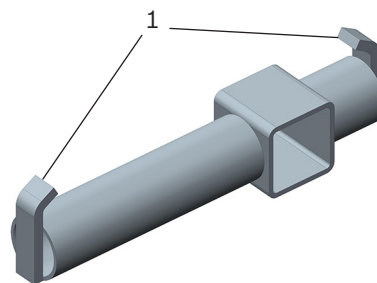

Fig. 4: Adapter 10-222A/18

1 Safety stop

3.4 Adapter 10-222A/21

- ▶ Secure the height adjustment foot with the counter nut after adjusting the height.

4 Inspection and Maintenance

- ▶ Check the support bracket and the required accessories for visible damage such as signs of wear, deformation, breakages, cracks, and corrosion damages prior to each use. Check all threads, rubber coatings, and axial bearings for damage. If defects are noted on the support bracket, do not use it and immediately discard it.
- ▶ Spare parts are available on request. Use only original replacement parts.
- ▶ Please contact your 1st level support representative with any queries.

NOTICE

Modifications to this product which have not been expressly approved by the manufacturer will void any warranty. The manufacturer assumes no liability for personal injuries or damage to materials which occur as the result of improper use of this product.



Declaration of Conformity with the Machinery Directive 2006/42/EC, Annex II 1A

Manufacturer:	Bosch Automotive Service Solutions GmbH Am Dörrenhof 1 85131 Pollenfeld-Preith Germany			
Authorized to Compile the Technical Documents:	Bosch Automotive Service Solutions GmbH Am Dörrenhof 1 85131 Pollenfeld-Preith Germany			
Product Name:	Support bracket			
Product Type:	Load holding device			
Product Numbers:	10-222B			
	10-222A/4	10-222A/13	10-222A/21	10-222A/28-2
	10-222A/5	10-222A/14	10-222A/22	10-222A/29
	10-222A/6	10-222A/15	10-222A/23	10-222A/30
	10-222A/7	10-222A/16	10-222A/23-1	10-222A/31A
	10-222A/8	10-222A/16-1	10-222A/25	10-222A/32
	10-222A/9	10-222A/17	10-222A/26	10-222A/34
	10-222A/9-1	10-222A/18	10-222A/27	10-222A/35
	10-222A/10	10-222A/19	10-222A/28	10-222A/36
	10-222A/12	10-222A/20	10-222A/28-1	

We hereby declare that the product described above complies with the relevant clauses of the 2006/42/EC Machinery Directive.

Any modification to a product not expressly approved by the manufacturer will void the validity of this declaration.

The following harmonized standards have been applied:

EN ISO 12100:2010	Safety of machinery - General principles for design - Risk assessment and risk reduction
EN 13155:2003+A2:2009	Cranes - Safety - Non-fixed load lifting attachments

Pollenfeld, 2019-01-25

Place, Date

Matthias Wagner,
Managing Director